

MOD / code	A	B	C	C1	D	E	F	G	H	I	L	M	N	O	P	Q	R	S
HPR3.0 F0101-00P090	50	100	19	-	-	-	6	M5x0.8x6	80	-	-	M4x0.7x6	OR.3050	16m	M16x1.5	35	45	7
HPR3.2 F0101-00P100	50	110	19	-	-	-	6	M5x0.8x6	80	-	-	M4x0.7x6	OR.3050	16m	M16x1.5	35	45	7
HPR3.4 F0101-00P110	60	120	19	-	-	-	6	M5x0.8x6	80	-	-	M4x0.7x6	OR.3050	16m	M16x1.5	35	45	7
HPR3.6 F0101-00P120	70	140	25	-	-	-	7	M5x0.8x6	100	-	-	M4x0.7x6	OR.3050	16m	M16x1.5	35	45	7
HPR3.8 F0101-00P130	70	154	25	-	60	20	7	M5x0.8x6	100	-	-	M4x0.7x6	OR.3050	16m	M16x1.5	35	45	7

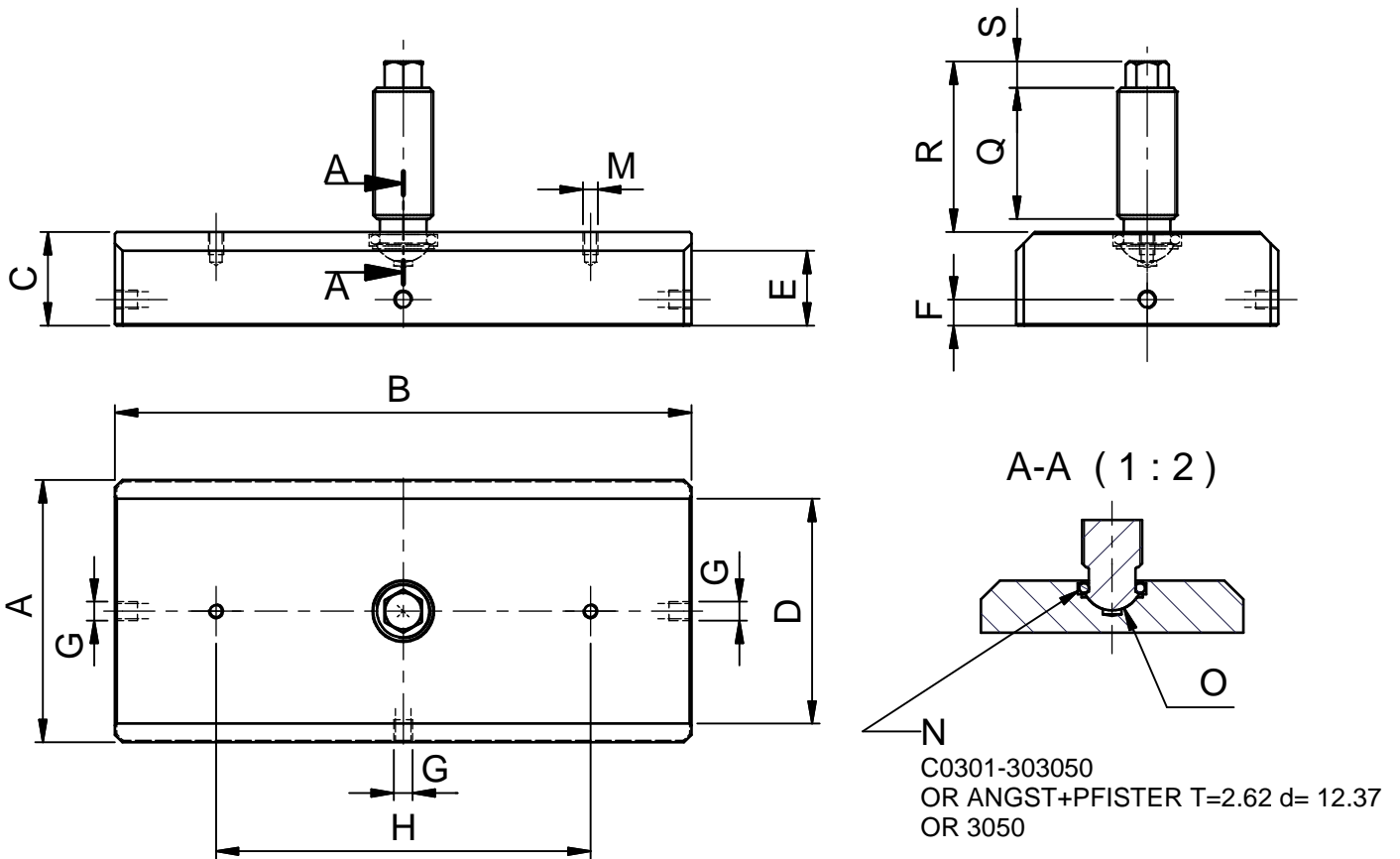

HEXAGON 10

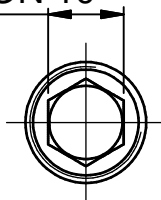

SL101-200030

PIVOT 16 M THREAD M16xL35 STANDARD

